

**Rikaline** E-705

# GPS Receiver

## User's Guide

Oct. 06, 2002

**Rikaline** Marketing Corp.

4F-11, 26, Tai Yuen St., Chu Pei, Hsin Chu, Taiwan  
Phone: +886-3-552-6001 Fax: +886-3-552-6002  
E-Mail: [info@rikaline.com.tw](mailto:info@rikaline.com.tw) Web: [www.rikaline.com.tw](http://www.rikaline.com.tw)

All Right Reserved

## TABLE OF CONTENTS

<b>1. Introduction</b> .....	<b>3</b>
1.1 Overview .....	<b>3</b>
1.2 Features .....	<b>3</b>
1.3 Technical Specifications .....	<b>3</b>
<b>2. Operational Characteristics</b> .....	<b>5</b>
2.1 Initialization .....	<b>5</b>
2.2 Navigation .....	<b>5</b>
<b>3. Hardware Interface</b> .....	<b>6</b>
3.1 Dimension .....	<b>6</b>
3.2 Hardware Interface .....	<b>6</b>
3.3 Connector .....	<b>6</b>
3.4 Accessories .....	<b>6</b>
<b>4. USB Driver</b> .....	<b>9</b>
4.1 System Requirements .....	<b>9</b>
4.2 Installation .....	<b>9</b>
4.3 Important .....	<b>9</b>
<b>5. Software Interface</b> .....	<b>10</b>
5.1 NMEA Transmitted Sentences .....	<b>10</b>
<b>6. Ordering Information</b> .....	<b>14</b>
6.1 Product Options .....	<b>14</b>
6.2 Accessories .....	<b>14</b>
<b>7. Warranty</b> .....	<b>14</b>

## **1. Introduction**

### **1.1 Overview**

The **E-705 GPS Receiver** integrated antenna is a total solution GPS receiver, designed based on EVERMORE on-chip hardware tracking loops technique for use in a wide range of application. This positioning application meets strict needs such as car navigation, mapping, surveying, security, agriculture and so on. Only clear view of sky and certain power supply are necessary to the unit. It communicates with other electronic utilities via compatible RS-232. With low power consumption, the **E-705** tracks up to 12 satellites at a time, re-acquires satellite signals in 100 ms and updates position data every second. The fast time-to-first-fix (TTFF) allows the unit operates with low power consumption.

### **1.2 Features**

The E-705 provides the following features:

1. Fast TTFF and low power consumption.
2. High performance receiver tracks up to 12 satellites.
3. Supports NMEA-0183 protocol.
4. Compact design ideal for applications requiring small space.
5. Optimized for navigation in urban-canyon environments.
6. Automatic cold start with no user initialization required.
7. Water resistance.

### **1.3 Technology specifications**

#### **1.3.1 Physical Dimension**

Single construction integrated antenna/receiver.

Size: 46.0(W) x 31.0 (D) x 15.6(H) (mm)  
1.81"(W) x 1.22"(D) x 0.61"(H).

#### **1.3.2 Environmental Characteristics**

- 1) Operating temperature: -20°C to +75°C(internal temperature).
- 2) Storage temperature: -55°C to +90°C.

#### **1.3.3 Electrical Characteristics**

- 1) Input voltage: +3.3 ~ 5.5 VDC.
- 2) Power consumption:  
100mA w/o power saving  
<80mA with power saving

#### **1.3.4 Performance**

- 1) Tracks up to 12 satellites.
- 2) Update rate: 1 second.
- 3) Acquisition time  
Reacquisition                      0.1 sec., averaged  
Interrupted Repositioning      8 sec., averaged  
Ephemeris update                40 sec., averaged
- 4) Position accuracy:  
Position                      5-25 meter CEP without SA  
Velocity                      0.1 meters/second, without SA  
Time                            1 microsecond synchronized GPS time
- 5) Dynamic Conditions:  
Altitude                        18,000 meters (60,000 feet) max

Velocity        515    meters / second (1000 knots) max  
Acceleration    4 G,    max

### **1.3.5 Interfaces**

- 1) PC interface: RS-232.
- 2) Baud rate: 4800/9600.
- 3) NMEA 0183 Version 2.2 ASCII output : GPGGA, GPGSA, GPGSV, GPRMC).

### **1.3.5 Coordinates System**

- 1) WGS84.

## **2. Operational Characteristics**

### **2.1 Initialization**

As soon as the initial self-test is complete, the E-705 begins the process of satellite acquisition and tracking automatically. Under normal circumstances, it takes approximately 40 seconds to achieve a position fix, 15 seconds if ephemeris data is known. After a position fix has been calculated, information about valid position, velocity and time is transmitted over the output channel.

The E-705 utilizes initial data, such as last stored position, date, time and satellite orbital data, to achieve rapid GPS signal acquisition and fast TTFF. If significant inaccuracy exists in the initial data, or the orbital data is obsolete, it may take more time to achieve a navigation solution or cold-start automatic-locate will be invoked. However, acquisition performance can be improved significantly if the host initializes the E-705 with a rough estimate of time and user position.

### **2.2 Navigation**

After the acquisition process is complete, the E-705 sends valid navigation information over output channels. These data include:

- 1) Latitude/longitude/altitude
- 2) Velocity
- 3) Date/time
- 4) Error estimates
- 5) Satellite and receiver status

The E-705 will perform 3D navigation when 4 or more satellites are tracked. When 3 or fewer satellites are tracked, altitude-hold is enabled using the last computed altitude and 2D navigation mode is entered.

With signal blockage or rising and setting of the satellites, where a change in satellite constellation used for position fix occurred, large position error may result. The E-705 incorporates a proprietary algorithm to compensate the effect of satellite constellation change, and maintains an accurate smooth estimate of the receiver's position, velocity, and heading.

### 3. Hardware interface

#### 3.1 Dimension

46.0(W) x 31.0 (D) x 15.6(H) (mm)  
 1.81"(W) x 1.22"(D) x 0.61"(H).

#### 3.2 Hardware Interface

The E-705 includes an antenna in a unique style water resistance gadget. Simply connect PS-2 female connector to your notebook PC, PDA or other devices.

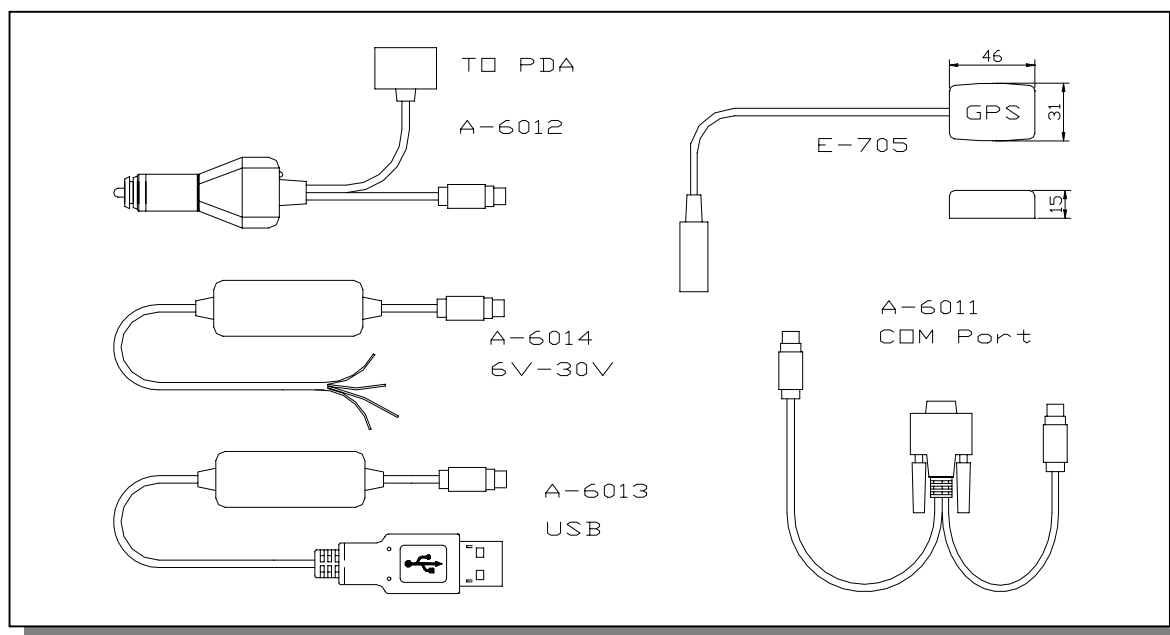

#### 3.3 Connector

Standard cable: 2 meters with COM port and male PS-2 connectors.

##### 3.3.1 Function definition of standard PS-2 composite connector

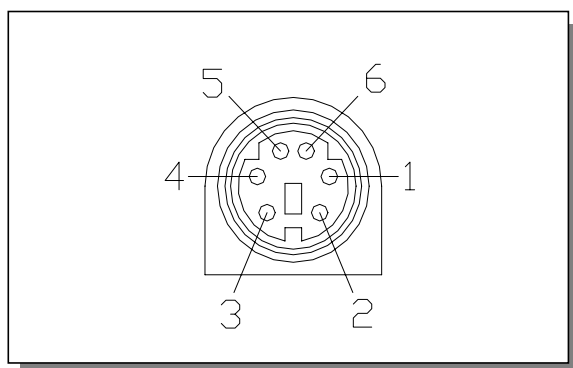

Pin	Signal
1	Tx (RS-232)
2	+5VDC
3	Tx (TTL)
4	Ground
5	1PPS
6	Rx (RS-232)

#### 3.4 Accessories

##### 3.4.1 A-6011 Mini Din Female and PS-2 male connector:

Cable Length: To E-705: 1 meter  
 RS-232 to PS-2: 45 cm

**3.4.1.1 Mini Din Female connector function definition:**

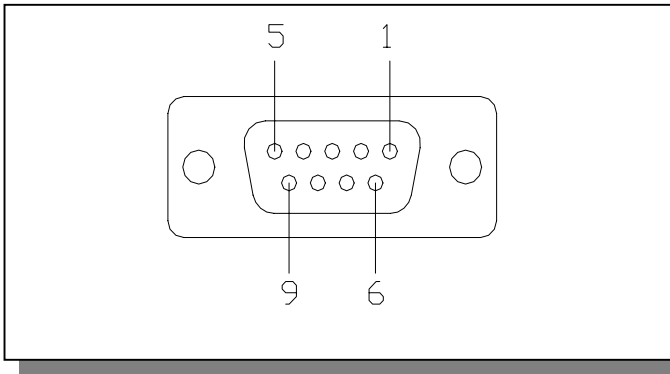

Pin	Signal Name
1	N.C
2	Tx
3	Rx
4	N.C
5	Ground
6	N.C
7	N.C
8	N.C
9	DGPS in

N.C = No connection

**3.4.1.2 PS2 composite connector function definition (to PC):**

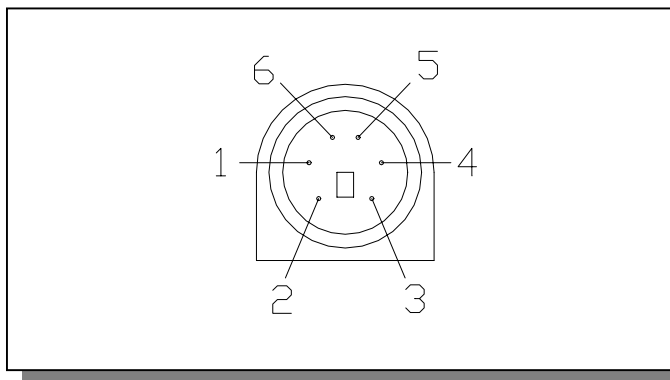

Pin	Signal Name
1	+5V
2	N.C
3	N.C
4	Ground
5	N.C
6	N.C

N.C = No connection

**3.4.2 A-6012 Cigarette adapter and PDA connector:**

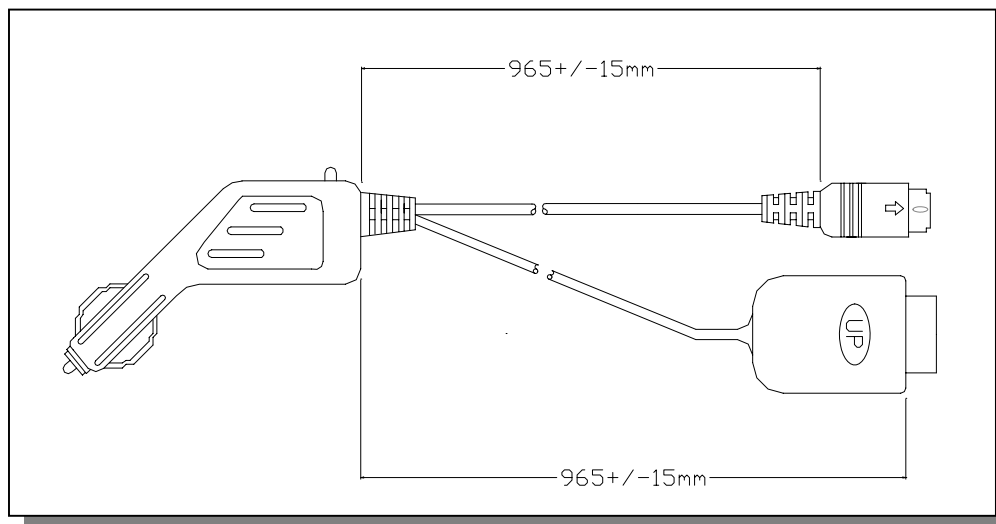

Part No.	Application
A-6017-A	ASUA
A-6017-B	BESTA I-WINNA
A-6012-H	HP Jornada
A-6017-L	Siemens LOOX
A-6017-M	Mitac Mio
A-6017-N	NEC

Part No.	Application
A-6012-P	Palm
A-6012-Q	I-Paq
A-6012-S	Sony Series
A-6017-T	Toshiba Series
A-6017-X	O2-XDA / T-Mobile - MDA

**3.4.3 A-6013 USB connector**

The function definition of the A Type USB connector is as follows:

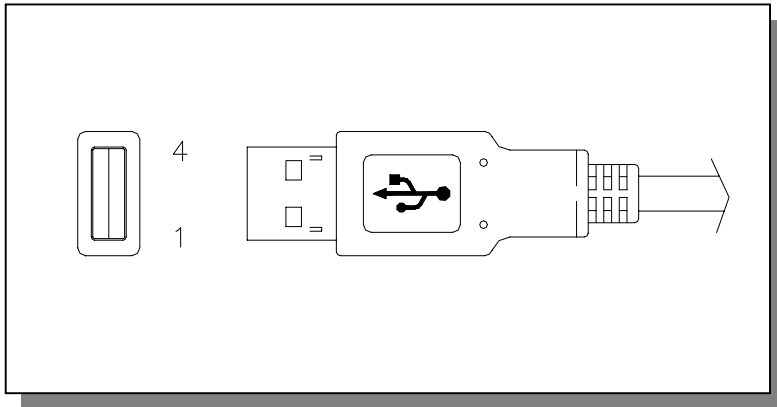

Pin	Signal Name
1	+5V
2	D +
3	D -
4	Ground

**3.4.4 A-6014 High power connector**

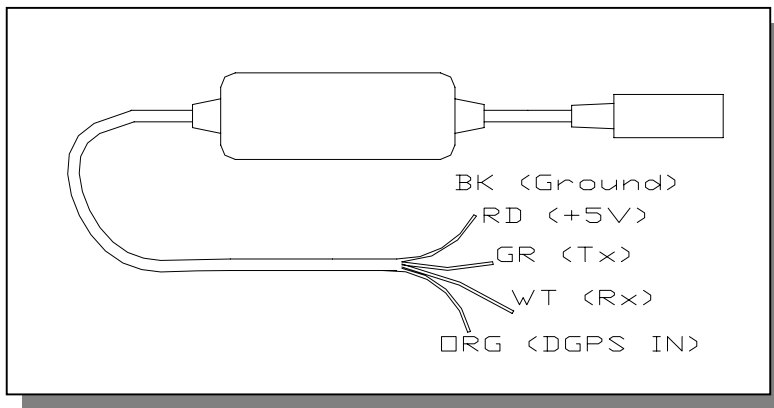

Color	Signal
Black	Ground
Red	+6~30 VDC
Green	Tx
White	Rx
Orange	DGPS IN

**3.4.5 A-6016 Cigarette Adapter**

Input power: 12-26VDC

Cable Length: 2 meter core type



## **4. USB Driver**

### **4.1 System Requirements**

IBM, Pentium or above and other compatible PC; 16 MB and above memory; Windows 98/Me/2000/XP; VGA Graphic Adapter.

### **4.2 Installation**

1. Copy entire <E-705 USB> folder from CD to hard disk.
2. Connect E-705 USB connector to computer. While the computer automatically starts the installation program, please direct the driver to the <E-705 USB> folder.
3. After the installation is complete, go to <Device Manager> and select <Ports (COM & LPT)> to verify if a virtual COM port <USB to Serial Port> was created.

### **4.3 Important**

Verify the COM port # to start using your own navigating software.

1. Click <**Start**> menu, select <**Settings**>, then enter <**Control Panel**>.
2. After entering <**Control Panel**>, select <**System**>.
3. Select <**Device Manager**>.
4. Find the <**Connect Port**> and check the Virtual COM Port, which was created by the USB driver. Please note that the Virtual COM Port number might be different from every computer. Before using navigating software, please confirm the COM Port numbers created by your computer and provided by your navigation software. They must be the same Com Port numbers. Otherwise, the navigating software won't receive the satellite signal for the un-match COM Port setting.

## 5. Software Interface

The E-705 interface protocol is based on the National Marine Electronics Association's NMEA 0183 ASCII interface specification, which is defined in NMEA 0183, Version 2.2.

### 5.1 NMEA Transmitted Messages

The E-705 outputs data in NMEA-0183 format as defined by the National Marine Electronics Association (NMEA), Standard.

The default communication parameters for NMEA output are 4800 baud, 8 data bits, stop bit, and no parity.

**Table 5-1 NMEA-0183 Output Messages**

NMEA Record	Description
GPGGA	Global positioning system fixed data
GPGSV	GNSS satellites in view
GPRMC	Recommended minimum specific GNSS data
GPVTG	Course over ground and ground speed

#### 5.1.1 Global Positioning System Fix Data (GGA) Out put time, position and position – fix related data.

Table 5-2 contains the values for the following example:

**\$GPGGA,161229.487,3723.2475,N,12158.3416,W,1,07,1.0,9.0,M, , , ,0000\*18**

**Table 5-2 GGA Data Format**

Name	Example	Units	Description
Message ID	\$GPGGA		GGA protocol header
UTC Time	161229.487		Hhmmss.sss
Latitude	3723.2475		ddmm.mmmm
N/S Indicator	N		N=north or S=south
Longitude	12158.3416		dddmm.mmmm
E/W Indicator	W		E=east or W=west
Position Fix Indicator	1		See Table 5-3
Satellites Used	07		Range 0 to 12
HDOP	1.0		Horizontal Dilution of Precision
MSL Altitude	9.0	Meters	
Units of Altitude	M	Meters	
Geoid Separation		Meters	
Units	M	Meters	
Age of Diff. Corr.		second	Null fields when DGPS is not used
Diff. Ref. Station ID	0000		
Checksum	*18		
<CR> <LF>			End of message termination

**Table 5-3 Position Fix Indicator**

Value	Description
0	0 Fix not available or invalid
1	GPS SPS Mode, fix valid
2	Differential GPS, SPS Mode, fix valid
3	GPS PPS Mode, fix valid

Note: the NMEA checksum consists of a “\*” and two hex digits representing exclusive-OR of all the characters between, but not including, the “\$” and “\*” characters

### 5.1.2 Geographic Position with Latitude/Longitude (GLL)

Table 5-4 contains the values for the following example:

**\$GPGLL,3723.2475,N,12158.3416,W,161229.487,A\*2C**

**Table 5-4 GLL Data Format**

Name	Example	Units	Description
Message ID	\$GPGLL		GLL protocol header
Latitude	3723.2475		ddmm.mmmm
N/S Indicator	N		N=north or S=south
Longitude	12158.3416		dddmm.mmmm
E/W Indicator	W		E=east or W=west
UTC Position	161229.487		hhmmss.sss
Status	A		A=data valid or V=data not valid
Checksum	*2C		
<CR> <LF>			End of message termination

### 5.1.3 GNSS DOP and Active Satellites (GSA)

Table 5-5 contains the values for the following example:

**\$GPGSA,A,3,07,02,26,27,09,04,15, , , , , ,1.8,1.0,1.5\*33**

**Table 5-5 GSA Data Format**

Name	Example	Units	Description
Message ID	\$GPGSA		GSA protocol header
Mode 1	A		See Table 5-6
Mode 2	3		See Table 5-7
Satellite Used (1)	07		Sv on Channel 1
Satellite Used (1)	02		Sv on Channel 2
.....			....
Satellite Used			Sv on Channel 12
PDOP	1.8		Position Dilution of Precision
HDOP	1.0		Horizontal Dilution of Precision
VDOP	1.5		Vertical Dilution of Precision
Checksum	*33		
<CR> <LF>			End of message termination

(1) Satellite used in solution.

**Table 5-6 Mode 1**

Value	Description
M	Manual—forced to operate in 2D or 3D mode
A	2D Automatic—allowed to automatically switch 2D/3D

**Table 5-7 Mode 2**

Value	Description
1	Fix Not Available
2	2D
3	3D

### 5.1.4 GNSS Satellites in View (GSV)

Table 5-8 contains the values for the following example:

**\$GPGSV,2,1,07,07,79,048,42,02,51,062,43,26,36,256,42,27,27,138,42\*71**

**\$GPGSV,2,2,07,09,23,313,42,04,19,159,41,15,12,041,42\*41**

**Table 5-8 GSV Data Format**

Name	Example	Units	Description
Message ID	\$GPGSV		GSV protocol header
Number of Messages	2		Range 1 to 3
Message Number	1		Range 1 to 3
Satellites in View	07		Range 1 to 12
Satellite ID	07		Channel 1 (Range 1 to 32)
Elevation	79	degrees	Channel 1 (Maximum 90)
Azimuth	048	degrees	Channel 1 (True, Range 0 to 359)
SNR (C/No)	42	dBHz	Range 0 to 99, null when not tracking
....	....		
Satellite ID	27		Channel 4 (Range 1 to 32)
Elevation	27	degrees	Channel 4 (Maximum 90)
Azimuth	138	degrees	Channel 4 (True, Range 0 to 359)
SNR (C/No)	42	dBHz	Range 0 to 99, null when not tracking
Checksum	*71		
<CR> <LF>			End of message termination

**NOTE:** Items <4>, <5>, <6> and <7> repeat for each satellite in view to a maximum of four (4) satellites per sentence. Additional satellites in view information must be sent in subsequent sentences. These fields will be null if unused.

### 5.1.5 Recommended Minimum Specific GNSS Data (RMC)

Table 5-9 contains the values for the following example:

**\$GPRMC,161229.487,A,3723.2475,N,12158.3416,W,0.13,309.62,120598, ,\*10**

**Table 5-9 RMC Data Format**

Name	Example	Units	Description
Message ID	\$GPRMC		RMC protocol header
UTC Time	161229.487		hhmmss.sss
Status	A		A=data valid or V=data not valid
Latitude	3723.2475		ddmm.mmmm
N/S Indicator	N		N=north or S=south
Longitude	12158.3416		dddmm.mmmm
E/W Indicator	W		E=east or W=west
Speed Over Ground	0.13	Knots	
Course Over Ground	309.62	Degrees	True
Date	120598		ddmmyy
Magnetic Variation		Degrees	E=east or W=west
Checksum	*10		
<CR> <LF>			End of message termination

### 5.1.6 Course Over Ground and Ground Speed (VTG)

Table 5-10 contains the values for the following example:

**\$GPVTG,309.62,T, ,M,0.13,N,0.2,K\*6E**

**Table 5-10 VTG Data Format**

Name	Example	Units	Description
Message ID	\$GPVTG		VTG protocol header
Course	309.62	Degrees	Measured heading
Reference	T		True
Course		Degrees	Measured heading

Reference	M		Magnetic (1)
Speed	0.13	Knots	Measured horizontal speed
Units	N		Knots
Speed	0.2	Km/hr	Measured horizontal speed
Units	K		Kilometers per hour
Checksum	*6E		
<CR> <LF>			End of message termination

(1) All “course over ground” data are geodetic WGS84 directions.

### 5.1.7 Time & Date (ZDA)

Table 5-11 contains the values for the following example:

**\$GPVTG,114523.62,12,04,2001,10,34\*6E**

**Table 5-11 zda Data Format**

Name	Example	Units	Description
Message ID	\$GPZDA		ZDA protocol header
Hour, Min, Sec, Sub Sec	114523.62		Hhmmss.ss
Day	12		Day in UTC, 01to 12
Month	04		Month in UTC, 01 to 12
Year	2001		Year in UTC
Local Zone Hours	10		Local zone hours, +/- 13 hours
Local Zone Minutes	34		Local zone minutes, 0 to +59
Checksum	*6E		
<CR> <LF>			End of message termination

## 6. Ordering Information

### 6.1 Product Options

- E-705** With COM Port connector
- E-705-P** with PS-2 femal connector
- E-705-U** With USB connector

### 6.2 Accessories

- A-6011 Com Port connector (Standard, packed in color box)
- A-6013 USB connector
- A-6014 High power connector, 6-30VDC
- A-6015 Magnetic pad
- A-6016 Cigarette adapter

A-6012 / 6017 PDA connector with Cigarette Adapter

	Part No.	PDA
1	A-6017-A	ASUS A-600
2	A-6017-B	BESTA I-WINNA
3	A-6012-C	Casio E-115
4	A-6012-C1	Casio E-125
5	A-6012-C2	Casio E-200
6	A-6012-H	HP Jornada 565/568
7	A-6012-HS	HandSpring Treo
8	A-6012-HS1	HandSpring Visor\Prism
9	A-6012-HS2	HandSpring Edge
10	A-6017-L	Siemens LOOX
11	A-6017-M	Mitac Mio 528
12	A-6017-N	NEC 300E
13	A-6012-P	Palm Vx
14	A-6012-P1	Palm / IBM WorkPad 500/505
15	A-6012-Q	I-Paq 36xx
16	A-6012-Q1	I-Paq 38xx
17	A-6017-Q1	I-Paq 38xx
18	A-6012-S	Sony N-7xx
19	A-6012-S1	Sony T-6xx
20	A-6017-SM	Siemens SX-45
21	A-6012-T1	Toshiba E-570
22	A-6017-T2	Toshiba E-330/740
23	A-6017-X	O 2 – XDA / T-Mobiles – MDA

**Remarks:** A-6012 series is 500mA  
A-6017 series is 2A

## 7. Warranty

The E-705 is warranted to be free from defects in material and functions for one year from the date of purchase. Any failure of this product within this period under normal conditions will be replaced at no charge to the customers.